

SW50-100A/B SCHEMATIC DIAGRAM

Display section

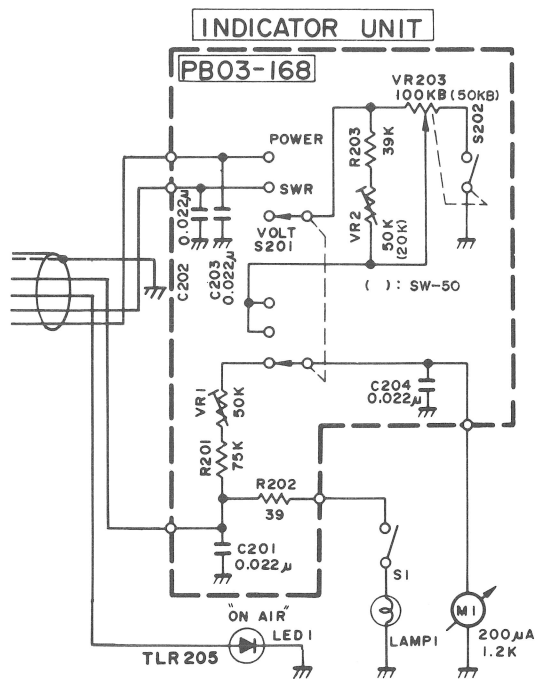

Coupler section

SW50-100A

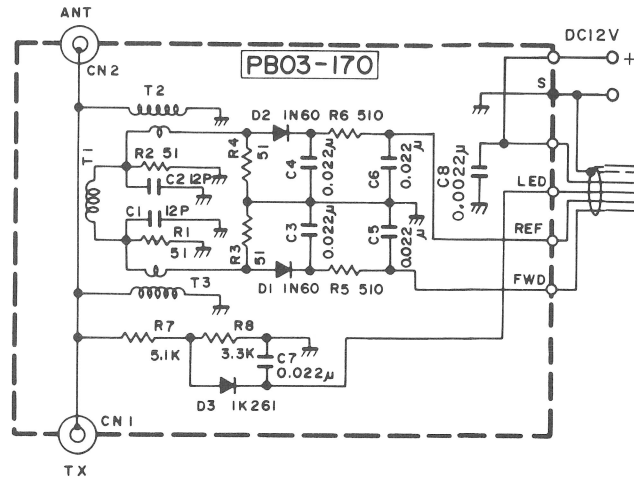

SW50-100B

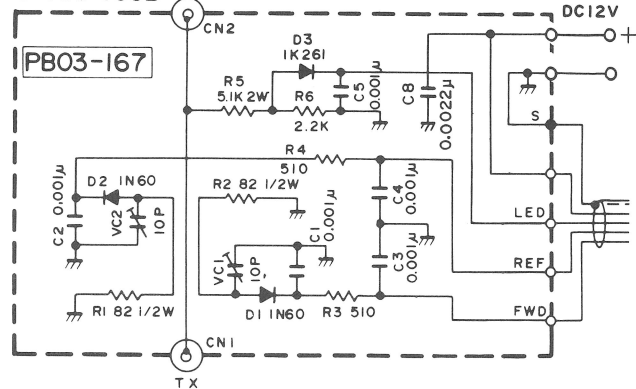

SW50-100A/B SPECIFICATIONS

	SW50-100A	SW50-100B
Impedance	50-52Ω	
Frequency range	1.8-150MHz	140-450MHz
Power meter range	0-150W	
Power measurement accuracy	±10% (full scale)	
Over load [Coupler]	150W continuous 300W PEP	100W continuous 200W PEP
SWR measurement range	1 : 1-1 : 3	
DC voltage measurement range	0-20V DC	
Insertion loss	Less than 0.3dB	Less than 0.5dB
Residual SWR	within 1.2	
Power	Less than 15V	
Connector	M type (SO-239)	
Coupler-Display cable length	Approx. 1.5m	
Dimensions [Coupler section]	W	H D
[Display section]	68 (2.68), 32 (1.26), 52 (2.05)	92 (3.62), 62 (2.44), 36 (1.42)
	() : Inch	
Weight [Coupler section]	Approx. 260g (0.6lbs)	
[Display section]	Approx. 90g (0.2lbs)	

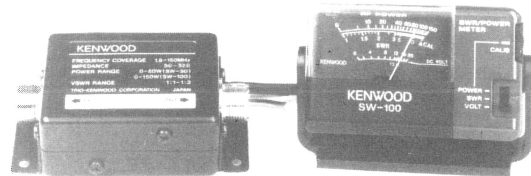

SW-50/100

KENWOOD